

@Smile

The Carbon Friendly Fan

Installation and Operating Instructions



- **5 models:**
 - SAP Appendix Q Eligible
3 speed continuous running
with or without filter
 - humidity control
 - SELV - low voltage:
 - 3 speed continuous
running
 - humidity control
- ***for all domestic wet rooms***
- ***for walls or ceilings***

CE  IPX4 IPX7

"E-Smile" - THE POWERFUL CARBON FRIENDLY FANS

INSTALLATION and OPERATING INSTRUCTIONS

THIS LEAFLET MUST BE AVAILABLE TO THE USER

The product you have purchased is an extractor fan for exhausting directly outside or through medium lengths of ducting and is suitable for wall or ceiling installation. To ensure optimum operation and guarantee a long life, please read this manual carefully. It explains how to install correctly, use and maintain the product properly. Following these instructions will ensure the reliability of the product and extend its working life.

The manufacturer will not be held responsible and will not accept any responsibility for damage caused to persons or things due to improper use with reference to the precautions outlined in this leaflet.

The product, constructed using state of the art technology, complies with current standards regarding electrical equipment. It conforms with the EMC 2014/30/EU European Directive regarding radio interference suppression and electromagnetic compatibility.

WARNING: Serious injury or death could result if these instructions are not carefully followed

- Do not use this product for any purpose other than that for which it was designed.
- Remove the product from its packaging and make sure that it has not been damaged. If in doubt, contact the supplier, authorised dealer, service centre or manufacturer to check that the product will still operate correctly. Do not attempt to use or repair the product before doing this.
- Do not leave packing material within the reach of children or unskilled people. To dispose of the packaging and the appliance at the end of its useful life refer to the recycling norms in force.

- The use of any electrical product requires compliance with some basic rules which are listed below:
 - do not touch it with wet or damp parts of the body (e.g hands, feet).
 - this appliance can be used by children aged from 8 years and above and persons with reduced physical, sensory or mental capabilities or lack of experience and knowledge if they have been given supervision or instruction concerning use of the appliance in a safe way and understand the hazards involved. Children shall not play with the appliance. Cleaning and user maintenance shall not be done by children without supervision.
- The product should be connected to the mains electricity supply or electrical outlet only if:
 - the electrical voltage and frequency correspond to those shown on the rating label.
 - the capacity of the electricity supply is sufficient to operate the product at its maximum power.
 - suitable electrical protection must be provided for the product to be installed.
- The electrical supply to which the fan is connected must comply with all existing regulations. All installations must comply with current IEE wiring regulations.
- Before maintenance or cleaning is carried out, the product must be switched off and disconnected from the mains electricity supply.
- If a fault, malfunction or anomaly of any type occurs, the fan should be isolated (switching it off and disconnecting it from the mains electricity supply) and advice sought from qualified personnel.

- Always request original spare parts for repairs
- If the product needs to be removed, turn off the mains supply circuit-breaker and then disconnect the fan.
- The fan **MUST BE** installed as detailed in this leaflet

WARNING: Damage could be caused to the product if the installation instructions are not followed

- The product should **not** be used in an ambient temperature higher than 40°C (104°F).
- The product should **not** be exposed to atmospheric agents (rain, sun, snow, etc.).
- The product or its parts should **not** be placed in water or other liquids.
- Routine maintenance as described below should be carried out to check the condition of the fan.
- The air or fumes being extracted must be clean and free from greasy particles, soot, chemical and corrosive agents, flammable or explosive mixtures.
- **The product must be installed by professionally qualified personnel. Incorrect installation can cause damage to people, animals or property, for which the manufacturer cannot be held liable.**
- The product must be connected to the electricity supply via a double pole switch of a suitable size, with contact openings of at least 3 mm.
- If the electrical supply board (or switching device) is located some distance from the fan a means of local isolation must be provided.
- To ensure optimum operation, do not block the air intake and exit vents.
- Any ducting used must be free of blockages.
- The room where the product is operating must have adequate air replacement to ensure maximum effectiveness.

- If the product is sited in a room containing a fuel burning appliance which is not of the balanced flue type, the installer must ensure that air replacement is adequate both for the fan and the fuel burning appliance.
- The product must **not** be used as an activator for water heaters, stoves, etc.
- The product must **not** exhaust into ducts designed to evacuate fumes from combustion in stoves or other combustion-powered devices.

RANGE

ES1003 - this fan combines the latest technology with energy saving and efficiency. It is a quiet running, 3 speed fan. It is designed to run continuously at a pre-selectable choice of 2 lower speeds (fixed at installation). The user can boost the fan speed to its maximum performance when required by means of the cord or remove the cord and use a remote switch, light switch, PIR sensor or humidistat. **The ES1003 is SAP Appendix Q Listed.**

ES1003CF - as above, but complete with metal filter.

ES100H2C - humidity control model - the fan will start to operate automatically at its lower speed when the relative humidity reaches the pre-set level and will continue to operate at this speed until the humidity has been dispersed. The user can use the cord or the remote switch (if the cord has been removed) to operate the fan (at its higher speed), or boost the fan speed if it is already running. Pulling the cord again (or switching off) will revert the fan to its lower speed, and it will continue to run either until the humidity has been removed, or the fan has completed the timer over-run period (adjustable between 3 and 25 minutes). The fan's "**comfortimer**" technology

allows the fan to run at low speed for its over-run period. The humidistat is adjustable from 40% to 90% relative humidity.

ES1003CLV - 12v SELV version of ES1003

ES100H2CLV - 12v SELV version of ES100H2C

INSTALLATION

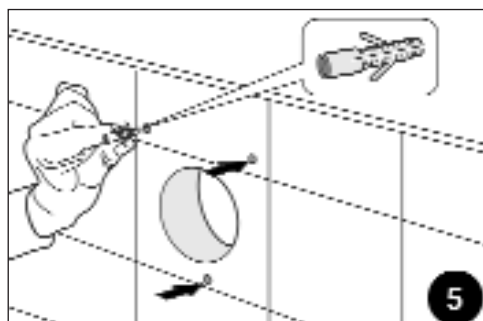
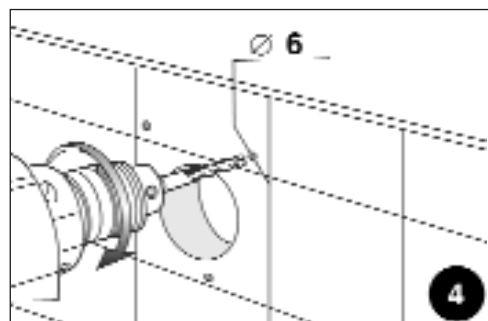
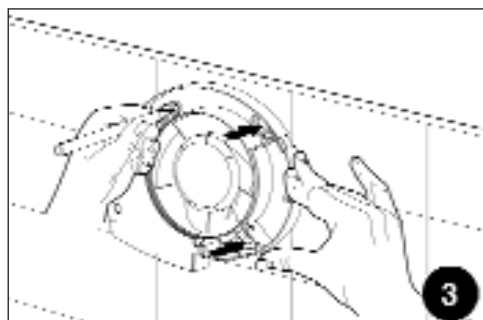
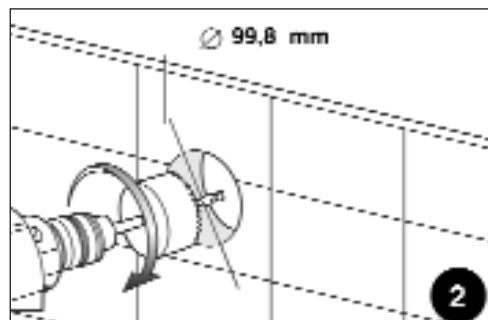
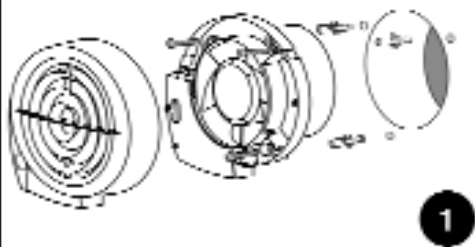

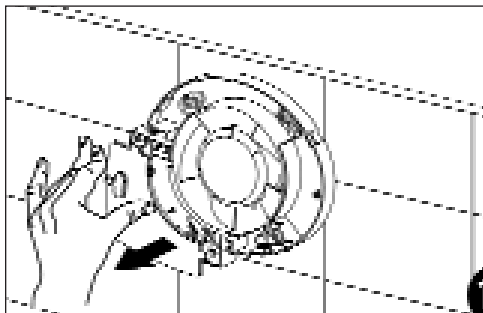
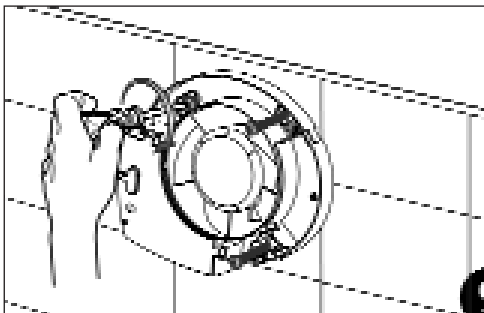
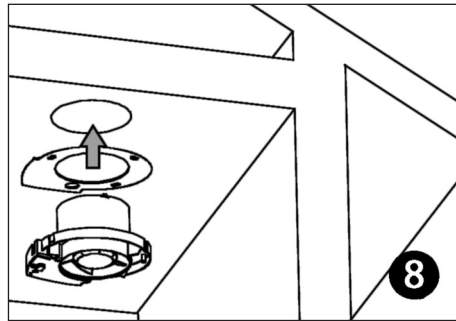
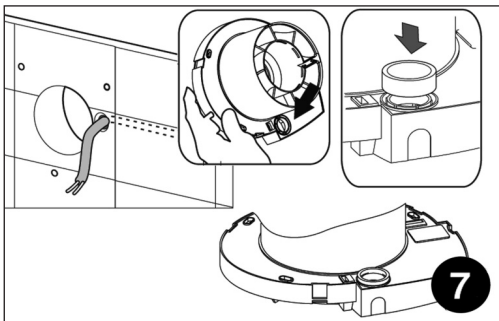
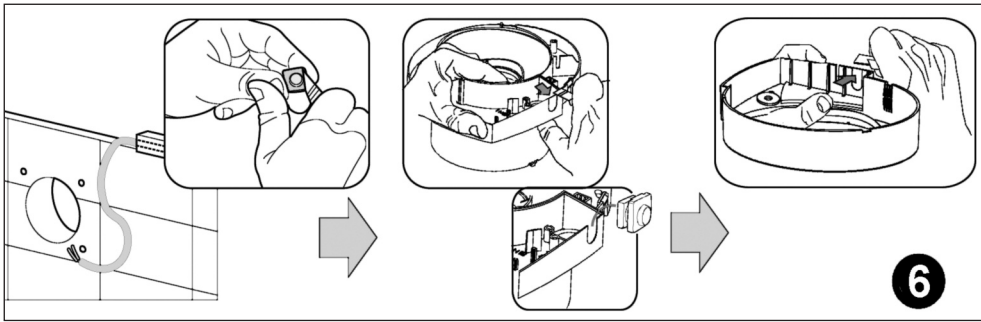

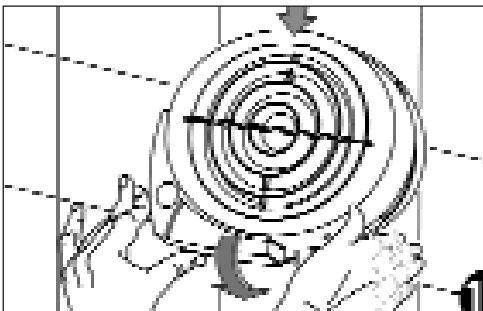
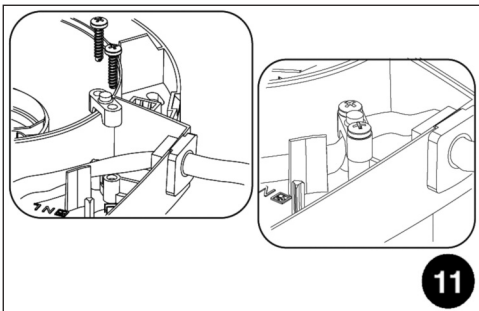

ES1003 - JUMPER SWITCH - 230v models

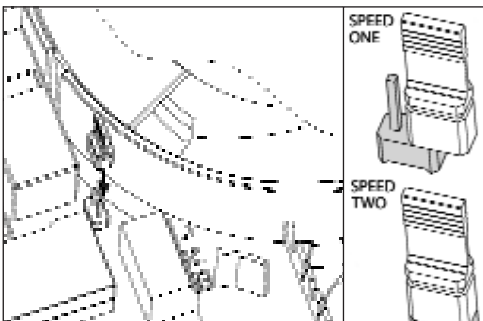

INSTALLATION

- Fig 1: check there is nothing missing in box and that instruction leaflet is included
- Fig 2: drill hole in wall - minimum dia 99.8mm - **allow extra width if using ducting - it is the installer's responsibility to use the appropriate core cutter to obtain the correct hole diameter.**
- Fig 3: use fan assembly as template to mark drill holes - **NB** fan can be at any angle
- Fig 4: drill 3 x 6mm dia holes
- Fig 5: fit wall plugs
- Fig 6: decide whether to have cable access from rear (recessed) or bottom (sur face) of fan - if from bottom ensure that included grommet is properly fixed
- Fig 7: if cable is to come through rear of fan, fit rubber ring (included)
- Fig 8: gasket included for ceiling installation
- Fig 9: screw fan to wall
- Figs 10, 11: make electrical connection using cable clamp
- Figs A: Wiring diagrams follow. **NB this fan is double insulated and does not need to be earthed**
- N.B This fan is NOT suitable for use with a Gravity Grille. It should be installed using either a Cowl or Fixed Grille.**
- Fig 12: Replace front cover

The ES1003 is designed to run continuously at one of 2 lower speeds fixed at installation using the jumper switch. Fan supplied ready for Speed 1 - lower speed. Installer can change to Speed 2 if required. The user can boost the fan speed to its maximum performance by using cord or remote switch (when installing with remote switch, pullcord switch must be left in "off" position and cord removed).

NOTE: SELV products have a 3 pin jumper-switch - see pages 8 and 9.

WIRING DIAGRAMS

ES1003 - 3 Speed with Cord

ES1003CF - 3 Speed with Cord & Filter

ES100H2C - Humidity Control with Cord

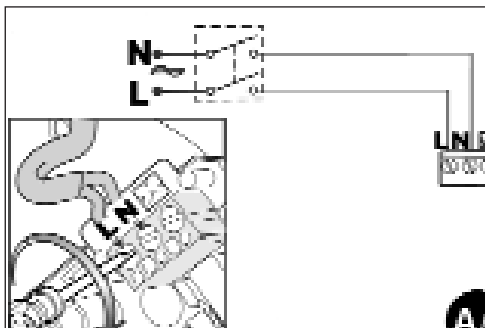

VIA LIGHT SWITCH

ES1003 - 3 Speed with Cord removed

ES1003CF - 3 Speed with Filter - Cord removed

ES100H2C - Humidity Control - Cord removed

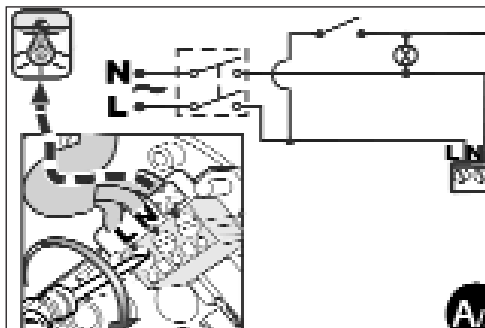

VIA REMOTE ILLUMINATED SWITCH

ES1003 - 3 Speed with Cord removed

ES1003CF - 3 Speed with Filter - Cord removed

ES100H2C - Humidity Control - Cord removed

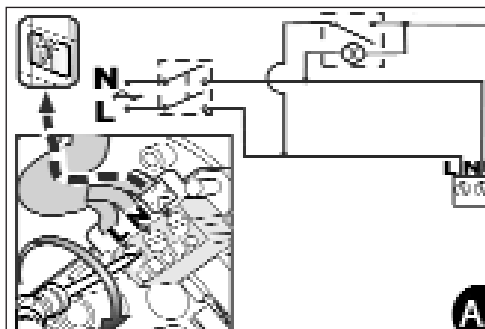

N.B When installing fans via a remote switch, pullcord switch must be left in "off" position and the cord removed.

SELV with Cord
ES1003CLV - 3 Speed with Cord
ES100H2CLV - Humidity Control with Cord

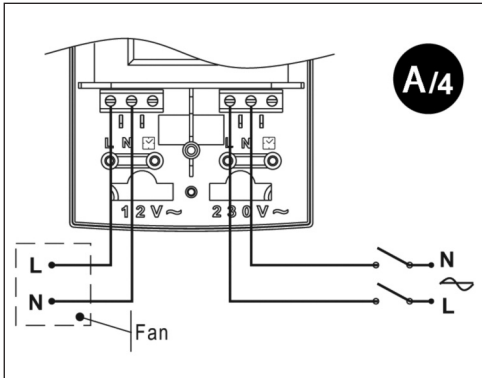

SELV with Cord removed
ES1003CLV - 3 Speed with Cord removed
ES100H2CLV - Humidity Control - Cord removed

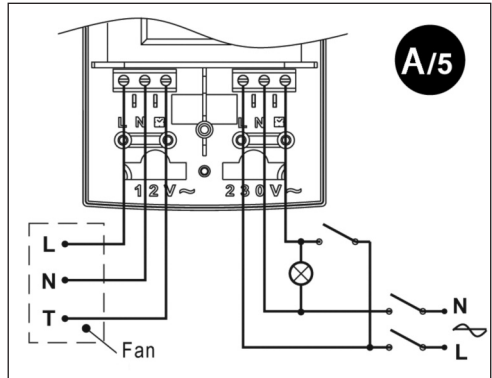

SELV Products

All SELV (safety extra low voltage) products must be installed to conform to IEC 60364.

- Connection between the fan and the mains supply must be by means of a safety isolating transformer of the appropriate power rating
- The transformer should be connected to the mains supply via a double pole safety switch with a contact opening of at least 3mm
- The transformer will operate only one fan
- The transformer must **not** be installed in Zones 1 or 2, but **should** be installed as close as possible to the fan within Zone 3
- The cable used to connect the transformer to the fan must be Class II, with a section area of at least 1.5mm² and a maximum length of 10m
- If the fan is a humidity control model, it must be installed using the transformer supplied for that product.

The ES1003 fans are designed to run continuously at one of 2 lower speeds fixed at installation using the jumper switch. The SELV models have 3 pins on the jumper switch (rather than 2 as on the 230v models) and are supplied ready for Speed 1 - lower speed. Installer can change to Speed 2 if required. The user can boost the fan speed to its maximum performance by using cord or remote switch (when installing with remote switch, pullcord switch must be left in "off" position and cord removed).

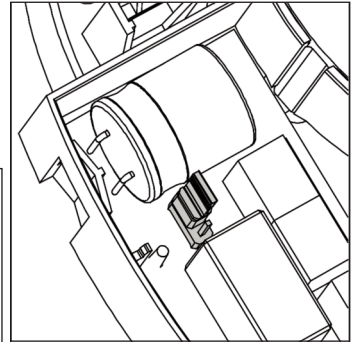
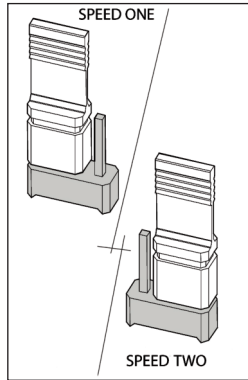
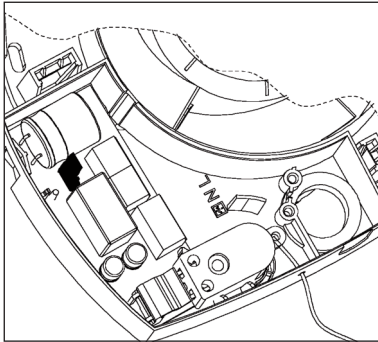

OPERATION

ES1003, ES1003CF, ES1003LV - these fans combine the latest technology with energy saving and efficiency. They are quiet running, 3 speed fans, designed to run continuously at a pre-selectable choice of 2 lower speeds (fixed at installation). The user can boost the fan speed to maximum performance when required by means of the cord. The fans can also be operated using a remote switch (light, PIR, humidistat, etc) instead of the cord. **The ES1003 is SAP Appendix Q Listed.**

ES100H2C and ES100H2CLV - humidity control models - the fans will start to operate automatically at their lower speed when the relative humidity reaches the pre-set level and will continue to

operate at this speed until the humidity has been dispersed. The user can use the cord to operate the fan (at its higher speed), or to boost the fan speed if it is already running. Pulling the cord again will revert the fan to its lower speed, and it will continue to run either until the humidity has been removed, or the fan has completed the timer over-run period (adjustable between 3 and 25 minutes). The fan's "**comfortimer**" technology allows the fan to run at low speed for its over-run period. The humidistat is adjustable from 40% to 90% relative humidity. The fans can also be operated using a remote switch instead of the cord (when installing with remote switch, pullcord switch must be left in "off" position and cord removed).

ADJUSTMENT OF TRIMMERS

To adjust the humidistat and timer trimmers, remove the front cover of the fan (Fig 13) and open the plastic cover to access the trimmers (Fig 14).

The humidistat can be adjusted (Fig 15) between 40% and 90% relative humidity. Turn clockwise

to decrease sensitivity and set at a higher level of relative humidity.

The timer is adjustable between 3 and 25 minutes. Turn the trimmer (Fig 16) clockwise to increase the overrun time, or anti-clockwise to decrease it.

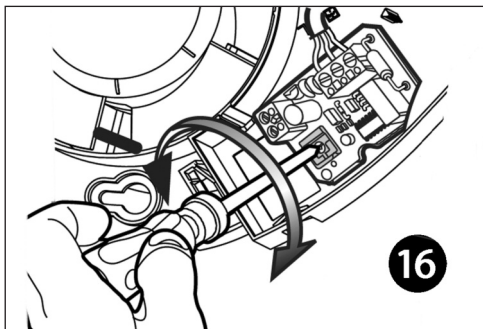
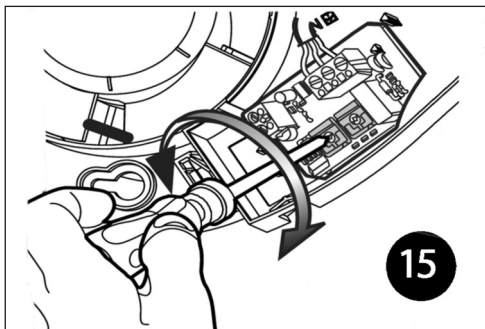
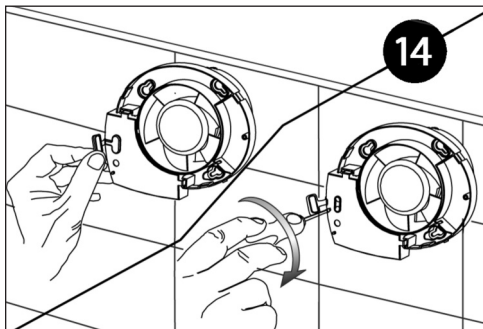
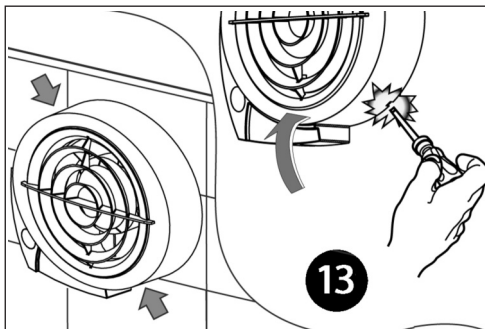

MAINTENANCE

Before any maintenance or cleaning operation, switch off the fan and disconnect it from the main power supply.

The front cover can be cleaned with a dry cloth or soft brush

The fan must not come into contact with any kind of liquid or solvent. If this should occur, contact a qualified technician before reassembling the fan.

NOTE: The motor does not require lubrication as it is maintenance free "sealed for life" type.

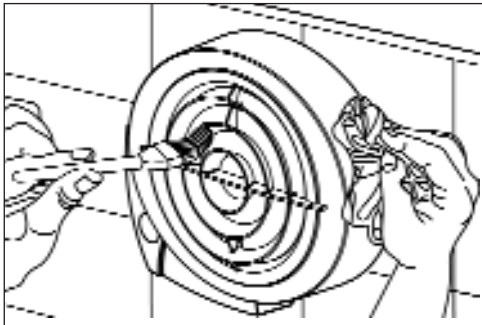
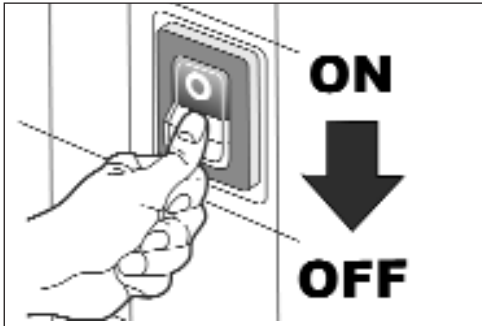

DISMANTLING & RECYCLING

This product has been designed and constructed using high-quality materials and components that can be recycled or re-used.

Vectaire Ltd, Lincoln Road, Cressex Business Park, High Wycombe, Buckinghamshire, HP12 3RH

Tel: +44 (0)1494 522333. Fax: +44 (0)1494 522337.

Email: sales@vectaire.co.uk Web: www.vectaire.co.uk